

BOUNDS FOR THE NONLINEAR

FILTERING PROBLEM

BY

VICTOR FRANKLIN KLEBANOFF

A.B., UNIVERSITY OF CALIFORNIA,

BERKELEY, 1972

Submitted in Partial Fulfillment

of the Requirements for the

Degree of Master of Science

at the

MASSACHUSETTS INSTITUTE OF TECHNOLOGY

May, 1976

Signature of Author. *V. Klebanoff*.....

Department of Mathematics,

May 7, 1976

Certified by.....

Thesis Supervisor

Accepted by.....

Chairman, Departmental Committee



ABSTRACT

Title of Thesis: Bounds for the Nonlinear Filtering Problem

Author: Victor Franklin Klebanoff

Submitted to the Department of Mathematics on May 7, 1976, in partial fulfillment of the requirements for the degree of Master of Science.

Known bounds for the optimal filtering error of the general nonlinear filtering problem are discussed. The example of the phase-tracking problem is used as an illustration. For the special case of the phase-tracking problem, new arguments are used to derive an upper bound for the optimal filter error.

Thesis Supervisor: Alan S. Willsky

Title: Assistant Professor of Electrical Engineering

ACKNOWLEDGEMENTS

It is a pleasure to acknowledge the help of Professor Alan Willsky, who supervised this thesis, as well as to thank him for his support and friendship.

In addition, I wish to thank my friends in the Experimental Studies Group for the delightful opportunity to teach in the program for the past two years.

Thanks are also due to Jiri Dadok, Emden Gansner, and Alfred Magnus for many interesting and helpful conversations.

CONTENTS

	Page
1. Background and Orientation	5
1.1 The nonlinear filtering problem	5
1.2 A specific class of nonlinear filtering problems	8
2. The Phase-tracking Problem: Introduction	11
3. Bounds on Estimator Error: General Results Applied to the Phase-tracking Problem	13
4. Bounds on an Error Criterion for the Optimal Filter for the Phase-tracking Problem	23
4.1 Study of the error criterion $E(1-\cos(\theta-\hat{\theta}))$	24
4.2 A stochastic differential equation for $ c_n(t) ^2$	25
4.3 Asymptotic behavior of the optimal filter error	28
4.4 Bounds for the phase-tracking problem	32
4.5 A conjecture and generalizations; a partial result; a counterexample	39
4.6 Strengthening the bounds	44
4.7 Comparison of results	47
5. Conclusions	52
References	53
Figure 1	21
Figure 2	21
Figure 3	22
Figure 4	38
Figure 5	38
Figure 6	46
Figure 7	51

1. Background and Orientation

1.1 The nonlinear filtering problem

The general nonlinear filtering problem has the following form: there is a signal process x_t which satisfies the Ito stochastic differential equation

$$dx_t = A(t,x) dt + B(t,x) dw_t$$

and a noisy observation process

$$dy_t = C(t,x) dt + D(t,x) dv_t$$

where $x \in \mathbb{R}^n$, $y \in \mathbb{R}^m$, and w_t and v_t are independent standard Brownian motion processes. The goal is to obtain an estimate x_t based on the observations y_s , for $0 \leq s \leq t$.

The least squares estimate of x_t is the \mathcal{F}_t -measurable random variable \hat{x}_t which minimizes the expectation

$$E([x_t - \hat{x}_t]^T [x_t - \hat{x}_t]),$$

where \mathcal{F}_t is the σ -field generated by the observations y_s , $0 \leq s \leq t$. It is well known that

$$\hat{x}_t = E(x_t | \mathcal{F}_t)$$

Moreover, x_t has the conditional probability density function $p(x,t)$, which satisfies the Kushner-Stratonovich equation (a stochastic integro-differential equation). For results concerning the solutions of this equation, the reader may consult, for example, the works of Fujasaki,

Kallianpur, and Kunita [3] and Levieux [7].

Problems associated with the Kushner-Stratonovich equation are (1) the impossibility of obtaining closed form solutions in the general case and (2) the excess of computing time required for application of numerical methods (despite proof (Levieux [7]) that under certain conditions, the solutions are sufficiently regular that numerical methods may be used).

By recalling the structure of the Kalman filter, we note another difficulty of the nonlinear filtering problem. For the linear problem, the optimal estimate is the solution of a linear stochastic differential equation

$$d\hat{x}_t = \tilde{A}\hat{x}_t dt + \tilde{B} dv_t$$

where the matrices \tilde{A} , \tilde{B} , and the Brownian motion process v_t depend only on the signal and observation processes. Furthermore, the error covariance, that is, the matrix-valued function

$$\Sigma(t) = E([x_t - \hat{x}_t][x_t - \hat{x}_t]^T)$$

solves a deterministic Riccati equation. This contrasts with the general case, for which a similar stochastic differential equation for the conditional expectation

$$\hat{x}_t = \int_{R^n} x \cdot p(x,t) dx$$

cannot be given. Rather, on writing the equation

$$d\hat{x}_t = \text{"right hand side"}$$

it happens that the right hand side involves second order conditional moments which are nondeterministic. Similarly, the stochastic differential equation for an n^{th} order conditional moment will have, on the right hand side, terms including $n+1^{\text{st}}$ order conditional moments.

The difficulties inherent in the nonlinear filtering problem suggest using filters which are suboptimal but finite dimensional. This makes it important to know the accuracy of such filters. For the nonlinear situation discussed above, where a least squares estimate is desired, the error

$$E([x_t - \tilde{x}_t]^T [x_t - \tilde{x}_t]),$$

for the suboptimal estimate \tilde{x}_t , trivially satisfies

$$E([x_t - \tilde{x}_t]^T [x_t - \tilde{x}_t]) \geq E([x_t - \hat{x}_t]^T [x_t - \hat{x}_t]).$$

We would necessarily like to know more.

To attack this problem, it is necessary, in principle, to compute

$$E([x_t - \hat{x}_t]^T [x_t - \hat{x}_t]).$$

This is, at best, very difficult. An alternative approach, considered by several authors, notably Bobrovsky, Zakai, and Ziv (working as collaborators) [1, 14] and Gilman and Rhodes [4, 5], has been to analytically bound this number. We shall show later, for a specific elementary, but highly nonlinear problem, that these bounds are not necessarily useful.

Simulations have been used in attempts to measure the estimator error (see Bucy [2] for results concerning the phase-lock loop, for example). Of course, in the absence of any analysis, it cannot be known how precise these measurements are.

1.2 A specific class of nonlinear filtering problems

As has been mentioned above, we are interested in nonlinear systems. A subclass of these which has received attention, by workers including Willsky and Marcus [8,13] is that of bilinear systems with linear observations.

These are systems of the form

$$dx_t = Ax_t dt + Bx_t dw_t$$

$$dy_t = Cx_t dt + dv_t$$

For several specific problems, the structure of optimal estimators has been analyzed and various approximations, which may serve as suboptimal filters, have been proposed. The reader may consult, for example, Willsky [12] for a discussion of these issues.

In what follows, we will discuss our efforts to understand the performance of the optimal filter for the following phase-tracking problem, which is perhaps the simplest bilinear problem.

Example: A particle on the unit circle in \mathbb{R}^2 undergoes Brownian motion, having begun at time $t=0$ at the point $(1,0)$. The x and y coordinates of the particle are observed during the passage of time, but the observations are not precise. Rather, they consist of the true coordinates, corrupted by additive noise, which is taken to be white noise. The Ito stochastic differential equations describing this situation are

$$d\theta = Q^{1/2}dv_t$$

$$dx = (\cos \theta)dt + R^{1/2}dw_1$$

$$dy = (\sin \theta)dt + R^{1/2}dw_2$$

where v , w_1 , and w_2 are independent standard Brownian motion processes and we impose the initial conditions

$$\theta(0)=0, \quad x(0)=1, \quad \text{and} \quad y(0)=0.$$

The filtering problem consists of finding a random variable $\hat{\theta}(t)$, which is an estimate of $\theta(t)$, based on the observations $x(s)$ and $y(s)$, for $0 \leq s \leq t$. Technically speaking, we require $\hat{\theta}(t)$ to be \mathcal{F}_t -measurable, where \mathcal{F}_t is the σ -field generated by the random variables $x(s)$ and $y(s)$, for $0 \leq s \leq t$. This estimate will typically be chosen to minimize some error criterion, for example the conditional expectation

$$E(|\theta(t) - \hat{\theta}(t)|^2 \mid \mathcal{F}_t)$$

$$\text{or} \quad E(1 - \cos(\theta(t) - \hat{\theta}(t)) \mid \mathcal{F}_t)$$

(Note that since $\theta(t)$ and $\hat{\theta}(t)$ are points on the unit circle, we identify $\theta(t)$ and $\theta(t)+2\pi$, and similarly for $\hat{\theta}(t)$.)

Remark: This is a problem of the class mentioned in section 1.2, with a bilinear system and linear observations.

It is, in fact, the same as the problem of obtaining

estimates $\hat{\alpha}_t$ and $\hat{\beta}_t$ for the system

$$d \begin{bmatrix} \alpha \\ \beta \end{bmatrix} = \begin{bmatrix} 0 & -1 \\ 1 & 0 \end{bmatrix} \begin{bmatrix} \alpha \\ \beta \end{bmatrix} Q^{1/2} dv_t - \frac{1}{2} \begin{bmatrix} \alpha \\ \beta \end{bmatrix} dt$$

with linear observations

$$dx = \alpha dt + R^{1/2} dw_1$$

$$\text{and } dy = \beta dt + R^{1/2} dw_2$$

(Note: the system equations are verified upon setting $\alpha = \cos \theta$, $\beta = \sin \theta$, and using the Ito differential rule to obtain the stochastic differential equations for α and β .)

2. The Phase-tracking Problem: Introduction

An optimal solution to the phase-tracking problem

We consider the Kushner-Stratonovich equation--the stochastic integro-differential equation for the conditional probability density of θ (conditioned on x_s and y_s , for $0 \leq s \leq t$)--for the phase-tracking problem of the example of section 1.2. It is

$$(KS) \quad dp_t = \frac{Q}{2} \frac{\partial^2 p}{\partial \theta^2} dt + \frac{p}{R^{1/2}} [\sin \theta - \widehat{\sin \theta} | \cos \theta - \widehat{\cos \theta}] \begin{bmatrix} dv_1 \\ dv_2 \end{bmatrix}$$

where

$$dv_1 = \frac{dy_t - (\widehat{\sin \theta}) dt}{R^{1/2}} \quad \text{and} \quad dv_2 = \frac{dx_t - (\widehat{\cos \theta}) dt}{R^{1/2}}$$

and, for any random variable u ,

$$\hat{u} = E(u | \mathcal{F}_t).$$

In (KS), $p(\theta, t)$ is the conditional probability density function of $\theta(t)$. We will study solutions of (KS) by using Fourier series. We expand

$$p(\theta, t) = \sum_{n=-\infty}^{\infty} c_n(t) e^{in\theta}.$$

The c_n are \mathcal{F}_t -measurable random variables. Upon substituting the series expansion into (KS), we obtain the infinite coupled system of stochastic ordinary differential equations

$$dc_n = -\frac{Qn^2}{2} c_n dt + \frac{1}{R^{1/2}} M_n \begin{bmatrix} dz_1 \\ dz_2 \end{bmatrix}$$

where

$$M_n = \begin{bmatrix} \frac{c_{n-1} - c_{n+1}}{2i} + c_n \operatorname{Im}(c_1) & \frac{c_{n-1} + c_{n+1}}{2} - c_n \operatorname{Re}(c_1) \end{bmatrix}$$

These equations suggest certain suboptimal estimators; we obtain, for example, an approximate filter upon ignoring all but a finite number of these equations (that is, set $c_n=0$, for $|n|$ sufficiently large).

3. Bounds on Estimator Error: General Results Applied to the Phase-tracking Problem

Survey of available results

In [14], Zakai and Ziv consider the problem of bounding the mean square error of the optimal estimator for a process of the form

$$\begin{aligned} dx_j &= x_{j+1}, \quad j=1,2,\dots,n-1 \\ dx_n &= m(x(t)) dt + B(x(t)) dw_t \end{aligned}$$

with the real-valued observation

$$dy_t = g(x_k(t)) dt + R^{1/2} dv_t$$

For the case when $x(t)$ is Gaussian, they obtain the lower bound

$$E([x_j - \hat{x}_j]^2) \geq E(\sigma_j(t)^2) \exp\left[-\frac{1}{R} \int_0^t E(o_g(s)^2) ds\right]$$

where

$$\sigma_g(t)^2 = E_{x(0)} \{ [g(x_k(t), t) - E_{x(0)} [g(x_k(t), t)]]^2 \}$$

and $\sigma_j(t)$ is the conditional (upon $x(0)$) variance of x_j .

Example: if $n=1$, $m(x)=0$, $B(x)=Q^{1/2}$, and $g(x)=\sin x$,

we have the phase-tracking problem, with only one observation.

For large t , $\sigma_g(t)^2$ is approximately equal to $1/2$,

since the probability density function of θ tends to a uniform distribution, as $t \rightarrow \infty$.

Also, $\sigma_1(t)^2 = Qt$, if we assume that $x(0)=0$. We deduce

that the lower bound is (asymptotically)

$$Q t \exp[-t/2Q],$$

evidently a useless result.

Moreover, the upper bound derived in the same paper is of no help, in this case, as it is valid only for the case $g(x)=x$, $j=k=n$.

A different type of result is due to Gilman and Rhodes [4, 5]. They consider the system

$$dx = f(x,t) dt + D(t) dv$$

$$dz = g(x,t) dt + G(t) dw$$

where v and w are independent standard Brownian motions and the functions f and g satisfy the so-called "cone-boundedness condition"

$$\| f(x+\delta, t) - f(x) - A(t)\delta \| \leq a(t) \|\delta\|$$

$$\| g(x+\delta, t) - g(x) - B(t)\delta \| \leq b(t) \|\delta\|$$

The Functions $A(t)$ and $B(t)$ parameterize an associated nominal linear system

$$dx = A(t)x dt + D(t) dv$$

$$dz = B(t)x dt + G(t) dw$$

The first result obtained by Gilman and Rhodes is an upper bound on the error covariance of the suboptimal filter

$$d\tilde{x} = f(\tilde{x}, t)dt + K(t) [dz - g(\tilde{x}, t)dt]$$

Their upper bound is

$$E([x(t) - \tilde{x}(t)] [x(t) - \tilde{x}(t)]^T) \leq P(t),$$

where $P(t)$ solves the differential equation

$$\frac{dP}{dt} = V + KWK^T + (A-KC)P + P(A-KC)^T + (a+c)P + (aI + CKK^T) \text{tr}P$$

Here $W=GG^T$ and $V=DD^T$ are assumed to be positive definite. Moreover, K may be chosen to minimize $P(t)$.

The second result, enunciated in [5], is the lower bound

$$E([x(t) - \tilde{x}(t)] [x(t) - \tilde{x}(t)]^T) \geq (1-r(t)) \hat{P}(t),$$

where $\hat{P}(t)$ is the error covariance of the Kalman filter for the associated nominal linear system. That is, it solves

$$\frac{d\hat{P}}{dt} = V + A\hat{P} + \hat{P}A - \hat{P}C^T W C \hat{P}$$

and $r(t) > 0$ solves

$$(1-r)e^r = e^{-d},$$

where

$$d(t) = \int_0^t [a^2(s) |V^{-1}(s)| + c^2(s) |W^{-1}(s)|] \text{tr}P(s) ds.$$

Example: For the phase-tracking problem,

$$f(x,t)=0, \quad D=Q^{1/2}, \quad g(x,t) = \begin{bmatrix} \cos x \\ \sin x \end{bmatrix}, \quad G=R^{1/2}I_2, \quad I_2 = \begin{bmatrix} 1 & 0 \\ 0 & 1 \end{bmatrix}$$

Hence,

$$A=0, \quad C=0, \quad a=0, \quad c=1, \quad W=RI_2, \quad \text{and} \quad V=Q.$$

Note: the fact that $c=1$ follows from the fact that

$$\left\| \begin{array}{l} \cos(x+\delta) - \cos x \\ \sin(x+\delta) - \sin x \end{array} \right\|^2 = 2[1 - \cos \delta] \leq \delta^2.$$

For the upper bound, we have, letting $K=[k_1 \quad k_2]$,

$$\frac{dP}{dt} = Q + RKK^T + P$$

This has the solution

$$\hat{P}(t) = P(0)e^t + (Q+RKK^T)(e^t-1)$$

But, K may be chosen to minimize $P(t)$. This is done by $K=0$, so that

$$P(t) = P(0) e^t + Q(e^t-1)$$

In particular, the upper bound tends to infinity as $t \rightarrow \infty$.

In addition, the lower bound which Gilman and Rhodes derive is not useful in this case:

$$\frac{d\hat{P}}{dt} = Q, \text{ so } \hat{P}(t) = Qt + \hat{P}(0)$$

$$\text{and } d(t) = \int_0^t \frac{\hat{P}(s)}{R} ds \approx \frac{Qt^2}{2R}, \text{ as } t \rightarrow \infty.$$

Now, $(1-r)e^r = e^{-d}$, whence for large t ,

$$r(t) \approx 1 - \exp\left[-1 - \frac{Qt^2}{2R}\right].$$

Hence, the lower bound is asymptotically

$$Qt \exp\left[-1 - \frac{Qt^2}{2R}\right],$$

which is not useful for large values of t .

Another general result, due to Zakai and Bobrovsky [1], shows that the estimation error for a given nonlinear problem is bounded below by the estimation error for an associated linear filtering problem. For the special case of estimating a Gaussian process from nonlinear measurements, their results coincide with those of Snyder and Rhodes [9].

Snyder and Rhodes consider the system

$$dx = F(t)x dt + V^{1/2}dv$$

$$y = H(t)x,$$

where y_t is the Gaussian Process to be estimated by the observation process

$$dz = h(t,y) dt + W^{1/2}dw$$

The result is that the optimal filter error satisfies

$$E([y(t) - \hat{y}(t)][v(t) - \hat{v}(t)]^T) \geq H(t)\Sigma(t)H(t)^T,$$

where $\Sigma(t)$ solves the Ricatti equation

$$\frac{d\Sigma}{dt} = F\Sigma + \Sigma F^T + V - \Sigma H^T P H \Sigma.$$

and $P(t) = E(J^T W^{-1} J)$,

for $J =$ the Jacobian of $h(t,y)$, (with respect to y).

Example: We illustrate the Snyder and Rhodes result by applying it to the phase-tracking problem:

We have $F=0$, $V=Q$, $H=1$, $h(t,y)=\sin(\omega t + y)$, and $W=R$.

Hence, $J=\cos(\omega t + y)$, so that

$$P(t) = \left(\frac{1}{R} \right) E(\cos^2(\omega t + y)) ,$$

hence, as $t \rightarrow \infty$,

$$P(t) \rightarrow \frac{1}{2R} .$$

Letting Σ_∞ denote the limit of Σ as $t \rightarrow \infty$, Σ_∞ solves the algebraic Ricatti equation

$$0 = Q - \frac{(\Sigma_\infty)^2}{2R} ,$$

whence the error for the optimal nonlinear filter for the phase-tracking problem is bounded below by $\sqrt{2QR}$.

For completeness, solely in connection with the phase-tracking problem, we discuss the classical phase-lock loop. As discussed in Van Trees [10], this system may be used to attack the problem of estimating a signal θ , from a noisy observation

$$s(t) = \sin(\omega t + \theta) + \frac{dw}{dt} .$$

We suppose that θ_t and w_t are independent Brownian motion

processes with covariances of Q_t and R_t , respectively. Note that θ_t is restricted to the unit circle, so θ and $\theta+2\pi$ are identified.

The structure of the phase-lock loop is shown in Figure 1. The voltage controlled oscillator (VCO) is a device whose output, given input $\frac{df}{dt}$, is $\cos(\omega t + f(t))$. In [10, 11, 12], it is shown that the system of Figure 2 may be used to model the phase-lock loop. Heuristically, this is because the signal fed into the low-pass filter is

$$\begin{aligned} & [\sin(\omega t + \theta) + \frac{d\omega}{dt}] \cos(\omega t + \hat{\theta}) \\ &= \frac{1}{2} [\sin(2\omega t)] \cos(\theta - \hat{\theta}) + \frac{1}{2} [1 + \cos(2\omega t)] (\sin \theta) (\sin \hat{\theta}) \\ & \quad - \frac{1}{2} [1 - \cos(2\omega t)] (\cos \theta) (\cos \hat{\theta}) \\ & \quad + \frac{d\omega}{dt} [\cos(\omega t + \hat{\theta})] \end{aligned}$$

The low-pass filter removes the double-frequency (that is, the $2\omega t$) terms and the last term is modelled as a white noise process $\frac{d\tilde{w}}{dt}$, where \tilde{w} has covariance $R_t/2$.

It follows that the system of Figure 2 models the phase-lock loop, provided that the noise process $\frac{d\tilde{w}}{dt}$ has strength $2R$.

We now discuss the mean square error for the phase-lock loop. We observe that if the operator "sine" is replaced by the identity, and if the gain function $F(s)$ equals the Kalman filter gain for the linear filtering problem

of estimating θ given the observation process z_t (where

$$dz_t = \theta dt + d\tilde{w})$$

the modified system is merely the Kalman filter for this problem. This value of $F(s)$ is used in the phase-lock loop.

Remark: A constant is the simplest choice of transfer function; with a gain of the form $F(s)=a+(b/s)$, the filter is called a second order loop.

It is possible to evaluate the asymptotic error covariance, that is

$$\lim_{t \rightarrow \infty} E(\{ \theta(t) - \hat{\theta}(t) \}),$$

for the phase-lock loop (where, for an angle ϕ ,

$$\{ \phi \} \triangleq \min_{k \in \mathbb{Z}} | \phi + 2k\pi |).$$

This is discussed in [10] and illustrated in Figure 3. In the graph of Figure 3, the straight line is the asymptotic error for the Kalman filter for the linear problem obtained by replacing the sine operator with the identity, as above. The curve is the asymptotic error for the phase-lock loop.

FIGURE 1

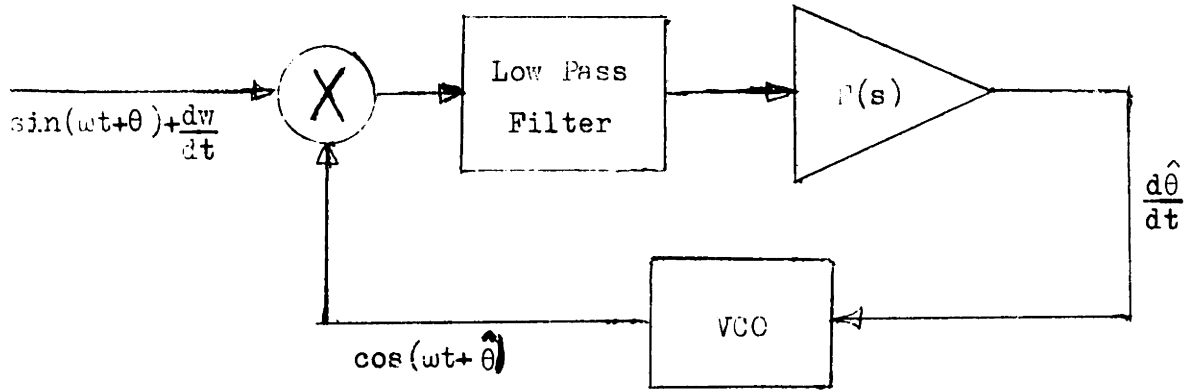

FIGURE 2

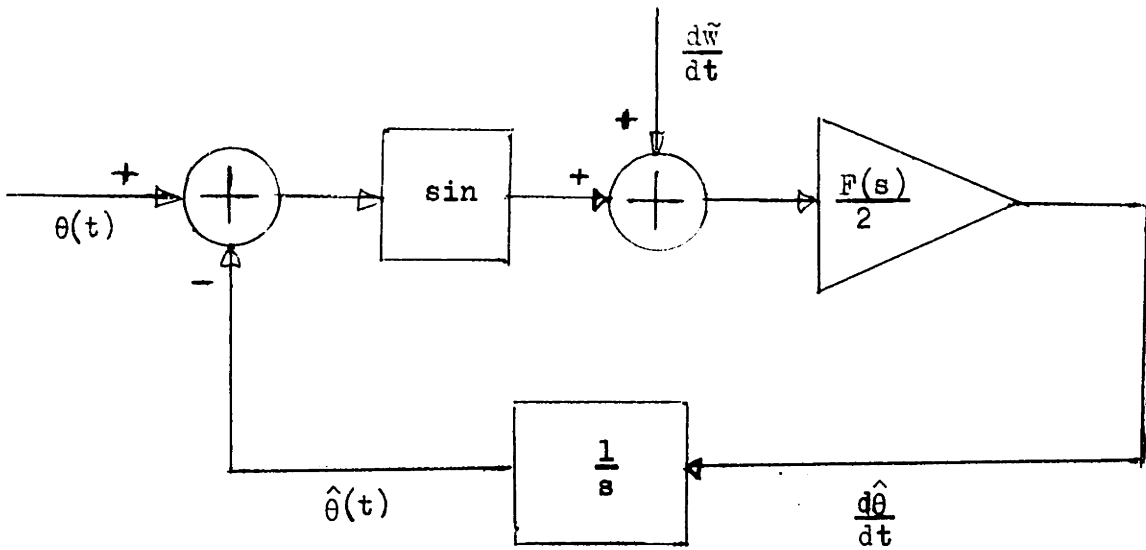
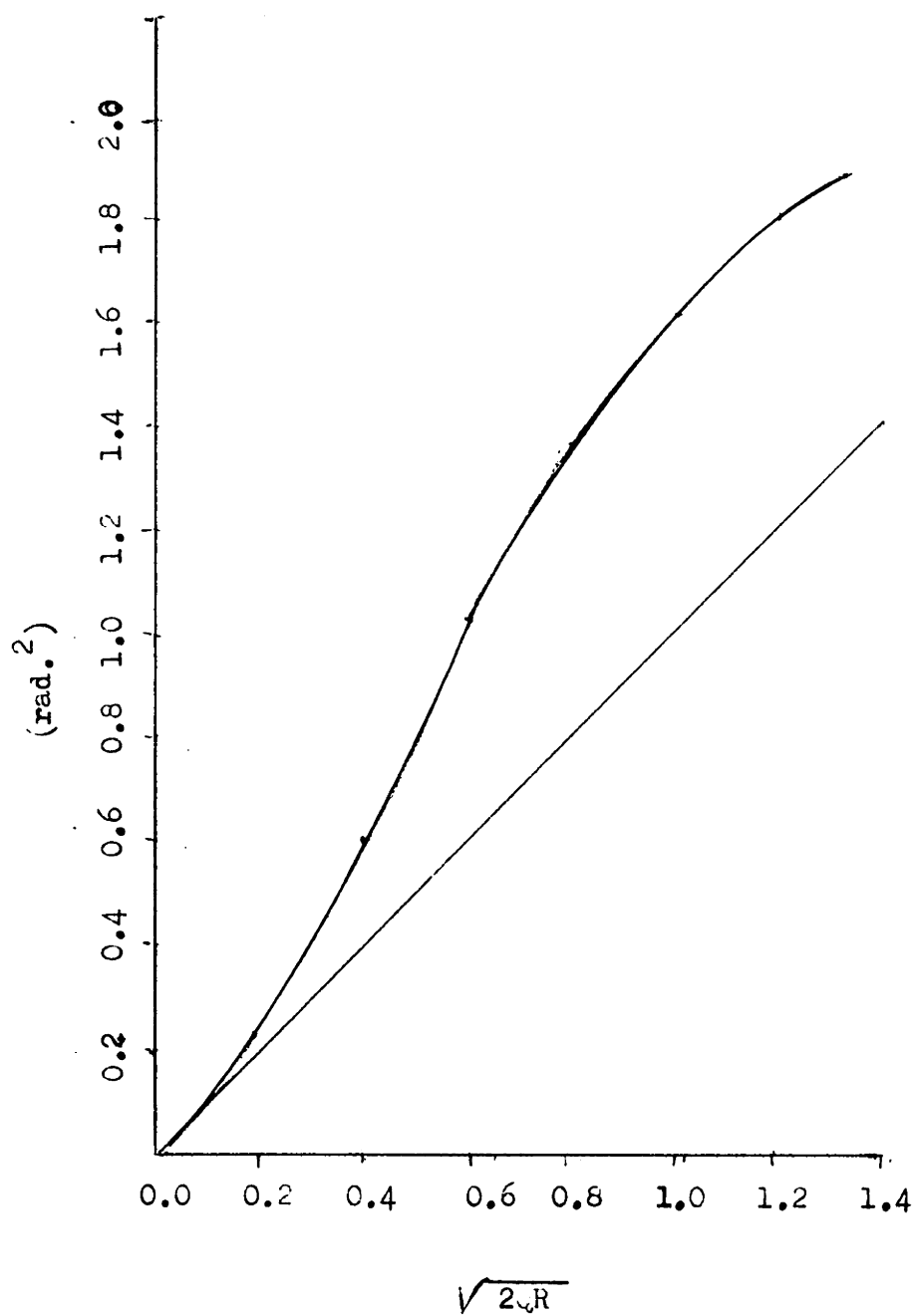

FIGURE 3



4. Bounds on an Error Criterion for the Optimal Filter for the Phase-tracking Problem.

We discuss, in this section, our efforts to find bounds for the error criterion

$$(1) \quad E(1 - \cos(\theta - \hat{\theta}))$$

for the phase-tracking problem introduced in section 1.

Section 4 is organized as follows:

- (a) We show that (1) depends only on the Fourier coefficient $c_1(t)$ of the series expansion of the conditional probability density $p(\theta, t)$, which is the solution of the Kushner-Stratonovich equation for the phase-tracking problem (see section 2).
- (b) We derive stochastic differential equations for $|c_n(t)|^2$, for all n .
- (c) We study the asymptotic behavior of $E(|c_n(t)|^2)$ and of related random variables.
- (d) We analyze the (algebraic) equations for the limits
$$I(|c_n|^2) \stackrel{\Delta}{=} \lim_{T \rightarrow \infty} \frac{1}{T} \int_0^T E(|c_n(t)|^2) dt$$
- (e) We state a conjecture and generalization, which might strengthen these bounds. Unfortunately, the conjecture and generalization together are generally false; we give a counterexample.

- (f) We give correct arguments motivated by the erroneous conjecture to strengthen the bounds obtained by the analysis described in (d).
- (g) We compare these results with those obtained by other workers using different methods for a related problem.

4.1. Study of the error criterion $E(1 - \cos(\theta - \hat{\theta}))$

In this subsection, we suppose that the random variable θ , with values on the unit circle, has the probability density function $p(\theta)$. The angle α is to be chosen to minimize

$$(2) \quad E(1 - \cos(\theta - \alpha));$$

we show that the minimal value of (2) is

$$1 - |c_1|,$$

where $p(\theta)$ has the Fourier expansion

$$p(\theta) = \sum_{n=-\infty}^{\infty} c_n e^{in\theta}$$

Thus, if we seek, for the phase-tracking problem, a random variable $\hat{\theta}$, which is

(a) \mathcal{F}_t -measurable

and (b) minimizes the conditional expectation

$$(3) \quad E(1 - \cos(\theta - \hat{\theta}) | \mathcal{F}_t),$$

then the minimum of (3) is $1 - |c_1|$, where $p(\theta)$ now represents

the conditional (with respect to \mathcal{F}_t) probability density function of θ (the Fourier coefficients are \mathcal{F}_t -measurable random variables). Therefore, the optimal choice of $\hat{\theta}$ will give

$$E(1 - \cos(\theta - \hat{\theta})) = 1 - E(|c_1|)$$

To verify that (2) is minimized by $1 - |c_1|$,

$$1 - \cos(\theta - \alpha) = 1 - \frac{1}{2}[e^{i(\theta - \alpha)} + e^{-i(\theta - \alpha)}].$$

Taking expectations,

$$E(1 - \cos(\theta - \alpha)) = 1 - \frac{1}{2}[c_{-1}e^{-i\alpha} + c_1e^{i\alpha}].$$

But $p(\theta)$ is real-valued, so $c_{-1} = \bar{c}_1$.

Hence, (2) = $1 - \text{Re}(c_1 e^{i\alpha})$, which is minimized when

$\text{Re}(c_1 e^{i\alpha}) = |c_1|$, as was to be shown.

4.2 A stochastic differential equation for $|c_n(t)|^2$

In this subsection, we will show that the following differential equation for $|c_n(t)|^2$ holds:

$$d|c_n|^2 = [-Qn^2 |c_n|^2 + \frac{1}{R} \left(\left| \frac{c_{n-1} - c_{n+1}}{2i} + c_n \text{Im}(c_1) \right|^2 + \left| \frac{c_{n-1} + c_{n+1}}{2} - c_n \text{Re}(c_1) \right|^2 \right)] dt$$

+ White Noise

Justification:

from section 2, we have,

$$dc_n = -\frac{Qn^2}{2}c_n dt + \frac{1}{R^{1/2}} \begin{bmatrix} g_1 & g_2 \end{bmatrix} \begin{bmatrix} dv_1 \\ dv_2 \end{bmatrix}$$

where v_1 and v_2 were defined in section 2, and

$$g_1 = \frac{c_{n-1} - c_{n+1}}{2i} + c_n \text{Im}(c_1)$$

$$g_2 = \frac{c_{n-1} + c_{n+1}}{2} - c_n \text{Re}(c_1)$$

Hence, taking complex conjugates,

$$d\bar{c}_n = -\frac{Qn^2}{2}\bar{c}_n dt + \frac{1}{R^{1/2}} \begin{bmatrix} \bar{g}_1 & \bar{g}_2 \end{bmatrix} \begin{bmatrix} d\bar{v}_1 \\ d\bar{v}_2 \end{bmatrix}$$

By the Ito calculus, we have

$$d|c_n|^2 = c_n d\bar{c}_n + \bar{c}_n dc_n + \frac{1}{2R} \text{tr} \begin{bmatrix} GQG^T \\ \begin{bmatrix} 0 & 1 \\ 1 & 0 \end{bmatrix} \end{bmatrix} dt$$

$$\text{where } G = \begin{bmatrix} g_1 & g_2 \\ \bar{g}_1 & \bar{g}_2 \end{bmatrix} \quad \text{and} \quad Q = \begin{bmatrix} 1 & 0 \\ 0 & 1 \end{bmatrix}$$

The desired equation follows from the observation that

$$\text{tr} \left(GQG^T \begin{bmatrix} 0 & 1 \\ 1 & 0 \end{bmatrix} \right) = 2(|g_1|^2 + |g_2|^2)$$

We now simplify the equation:

The term $(|g_1|^2 + |g_2|^2)$ is of the form

$$(4) \quad \left| \frac{A-C}{2i} + BI \right|^2 + \left| \frac{A+C}{2} - BH \right|^2$$

But, for complex z and ζ ,

$$|z + \zeta|^2 = |z|^2 + |\zeta|^2 + 2 \operatorname{Re}(z\bar{\zeta});$$

hence, (4) equals

$$\begin{aligned} \frac{|A|^2 + |C|^2}{2} + |B|^2(I^2 + H^2) - H \operatorname{Re}(A\bar{B}) + I \operatorname{Im}(A\bar{B}) \\ - H \operatorname{Re}(C\bar{B}) + I \operatorname{Im}(C\bar{B}) \end{aligned}$$

On setting $A=c_{n-1}$

$$B=c_n$$

$$C=c_{n+1}$$

$$H=\operatorname{Re}(c_1)$$

$$I=\operatorname{Im}(c_1)$$

and substituting into the stochastic differential equation

for $|c_n|^2$, we obtain

$$(5) \quad d|c_n|^2 = \frac{1}{R} \left[-QRn^2 |c_n|^2 + \frac{|c_{n-1}|^2 + |c_{n+1}|^2}{2} \right.$$

$$\left. + |c_1|^2 |c_n|^2 \right.$$

$$\left. - \operatorname{Re}(c_1 c_{n-1} \bar{c}_n + c_1 c_n \bar{c}_{n+1}) \right] dt$$

+ White noise

4.3 Asymptotic behavior of the optimal filter error

In this section, we obtain the result

$$\begin{aligned}
 (6) \quad \text{QRn}^2 \text{ I}(|c_n|^2) &= \frac{1}{2} [\text{I}(|c_{n-1}|^2) + \text{I}(|c_{n+1}|^2)] \\
 &\quad + \text{I}(|c_1|^2 |c_n|^2) \\
 &\quad - \text{Re} (\text{I}(c_1 c_n \bar{c}_{n+1} + c_1 c_{n-1} \bar{c}_n))
 \end{aligned}$$

where, for a polynomial q in the Fourier coefficients, c_n , of the conditional probability density function $p(\theta, t)$, the limit

$$\text{I}(q) \stackrel{\Delta}{=} \lim_{T \rightarrow \infty} \frac{1}{T} \int_0^T \text{E}(q(t)) dt$$

exists by a theorem of Kunita.

It is clear that (6) follows from (5) upon taking expectations, integrating with respect to t from 0 to T , dividing by T , and taking limits, provided that the limits exist. In the remainder of this section we justify taking the limits.

To explain Kunita's result, we require an abstract formulation of the filtering problem. We motivate the formulation with the example of the phase-tracking problem. The state space of the signal process is S^1 , the circle. The conditional probability density function, $p(\theta, t)$ may be

viewed as a stochastic process taking values (for each time t and each point ω in the underlying probability space Ω) in $C(S^1)$, the space of continuous, real-valued functions on S^1 . Moreover, for each ω and each t , $p(\cdot, t)$ is a probability density function, so it may be viewed as a probability measure on S^1 . This is the desired abstract formulation: the filtering process is a stochastic process taking values in $M(S^1)$, the space of probability measures on S^1 . We use π_t to denote the filtering process, so, for our example, $\pi_t = p(\cdot, t)$, where we suppress reference to Ω .

We now discuss the abstract problem. The signal process x_t has state space S , a compact separable, Hausdorff space. Let $M(S)$ be the set of all probability measures on S , endowed with the weak* topology (as the dual space of $C(S)$), under which it is a compact, separable, Hausdorff space. The filtering process π_t is an $M(S)$ -valued stochastic process with transition probabilities $\Pi_t(\nu, \Gamma)$. Kunita's results [6] (Theorems 3.1 and 3.3) give conditions under which there exists a unique invariant measure of the set of transition probabilities $\Pi_t(\nu, \Gamma)$. Recall that an invariant measure for the $\Pi_t(\nu, \Gamma)$ is a probability distribution, ϕ , on $M(S)$, satisfying

$$\phi(\Gamma) = \int \Pi_t(\nu, \Gamma) \phi(d\nu)$$

(Intuitively: the probability that, at time t , the value of the filter process is in Γ , equals the probability that it began in Γ at time zero.)

The phase-tracking problem satisfies the hypotheses of Kunita's theorems. Thus, there exists a unique, invariant measure, ϕ , for the filter process, given by

$$\phi(\Gamma) = \lim_{T \rightarrow \infty} \frac{1}{T} \int_0^T \Pi_t(v, \Gamma) dt .$$

For the phase-tracking problem, S is the circle, S^1 .

Suppose that $f: M(S^1) \rightarrow R$ is continuous. (As an example of such an f take any polynomial in the Fourier coefficients of the measure μ , for $\mu \in M(S^1)$; in particular, if the measure has the density function $p(\theta) = \sum_{n=-\infty}^{\infty} c_n e^{in\theta}$, let f be any polynomial in the c_n .)

For such a function f , we have, by definition,

$$E(f(\Pi_t) | \Pi_0 = v) = \int_{M(S^1)} f(a) \Pi_t(v, da)$$

So that

$$\begin{aligned} I(f) &= \lim_{T \rightarrow \infty} \frac{1}{T} \int_0^T E(f(\Pi_t) | \Pi_0 = v) dt \\ &= \lim_{T \rightarrow \infty} \frac{1}{T} \int_0^T \left[\int_{M(S^1)} f(a) \Pi_t(v, da) \right] dt \\ &= \int_{M(S^1)} f(a) \phi(da), \end{aligned}$$

by the Fubini Theorem and the fact that ϕ is defined as a

weak* limit.

Remark: This shows that the limit $I(f)$ exists for all functions f of interest for the phase-tracking problem. Moreover, it shows that I is a bona fide integral, that is, a continuous, real-valued, linear functional on $C(M(S^1))$.

4.4 Bounds for the phase-tracking problem

We begin this section by deriving, from equation (6), for $n=1$, several inequalities among the numbers $I(|c_1|^2)$, $I(|c_2|^2)$, and $I(|c_1|^4)$. We conclude the section by deducing, from these inequalities, a lower bound for $I(|c_1|)$.

This will give an upper bound for

$$\lim_{T \rightarrow \infty} \frac{1}{T} \int_0^T [1 - E(\cos(\theta(t) - \hat{\theta}(t)))] dt$$

for the phase-tracking problem.

Equation (6) for the case $n=1$ is

$$(7) \quad (1+QR) I(|c_1|^2) = \frac{1}{2} [1 + I(|c_2|^2)] + I(|c_1|^4) - I(\operatorname{Re}(c_1^2 \bar{c}_2))$$

We now obtain lower bounds on $I(|c_1|^2)$ and $I(|c_1|^4)$

and deduce lower bounds for $I(|c_1|)$.

We remark that, using the Holder inequality and the fact that $|c_n| \leq 1$, for all n ,

$$I(\operatorname{Re}(c_1^2 \bar{c}_2)) \leq I(|c_1^2 \bar{c}_2|) \leq \sqrt{I(|c_1|^4)} \cdot \sqrt{I(|c_2|^2)},$$

so that, from (7), we obtain

$$(8) \quad (1+QR) I(|c_1|^2) \geq \frac{1}{2} [1 + I(|c_2|^2)] + I(|c_1|^4) - \sqrt{I(|c_1|^4)} \cdot \sqrt{I(|c_2|^2)}.$$

Again, by Holder,

$$I(|c_1|^2) \leq \sqrt{I(|c_1|^4)},$$

so that, from (8), we have

$$(9) \quad (1+QR)\sqrt{I(|c_1|^4)} \geq \frac{1}{2}[1+I(|c_2|^2)] + I(|c_1|^4) \\ - \sqrt{I(|c_1|^4) \cdot I(|c_2|^2)}$$

Note that (9) is an inequality of the form $ax^2+bx+c \leq 0$, with $a > 0$, where $x = \sqrt{I(|c_1|^4)}$.

Hence, we conclude that $x \in [r_1, r_2]$, where r_1 and r_2 are the roots of the quadratic equation.

In this way, we deduce that

$$(10) \quad I(|c_1|^4) \geq w(\lambda) \triangleq \frac{1}{4} [(\lambda+1+QR) - \sqrt{QR+2QR(\lambda+1)-(1-\lambda)^2}]^2$$

where, henceforth, $\lambda = \sqrt{I(|c_2|^2)}$.

The following fact will be useful later:

$$(11) \quad \lambda \geq 1 + QR - \sqrt{QR(2+QR)}$$

We derive it from (9), which, after setting $x = \sqrt{I(|c_1|^4)}$, is

$$(1+QR)x \geq \frac{1+\lambda^2}{2} + x^2 - \lambda x,$$

whence

$$0 \leq (\lambda-x)^2 \leq -[1 + x^2 - 2(1+QR)x] = P(x)$$

Figure 4 illustrates the situation. Equation (11) is merely the observation that λ is greater than the smaller root of $P(x)$.

Also, (8) may be rewritten, in terms of λ , as

$$(12) \quad I(|c_1|^2) \geq \frac{1}{1+QR} \left[\frac{1+\lambda^2}{2} + I(|c_1|^4) - \lambda \sqrt{I(|c_1|^4)} \right].$$

In the remainder of this section, we will use some of the inequalities obtained above to deduce a lower bound for $I(|c_1|)$. The analysis takes the following course: For each value of λ , we show that the set of possible values of $(I(|c_1|^4), I(|c_1|^2))$ is a restricted region of \mathbb{R}^2 . From this, we deduce, assuming a particular value of λ , a lower bound for $I(|c_1|)$. Then, by minimizing this lower bound over all $\lambda \in [0, 1]$, we obtain a lower bound for $I(|c_1|)$.

More precisely, for each fixed value of λ , (12) gives a lower bound for $I(|c_1|^2)$, as a function of $I(|c_1|^4)$. In addition, we know

$$(13) \quad I(|c_1|^4) \leq I(|c_1|^2) \leq I(|c_1|),$$

because $|c_1| \leq 1$

and

$$(14) \quad I(|c_1|^2) \leq \sqrt{I(|c_1|^4)},$$

by the Holder inequality.

These facts are illustrated in figure 5, in which values of $I(|c_1|^4)$ are on the x-axis and values of $I(|c_1|^2)$ are on the y-axis. The shaded region represents the set of values of the pair $(I(|c_1|^4), I(|c_1|^2))$ allowed by (10), (12), (13), and (14). The numbers $z(\lambda)$ and $w(\lambda)$ are defined in the figure. The value of $w(\lambda)$ was given in (10);

$$z(\lambda) = \left[\frac{\sqrt{\lambda^2(1+2QR) + 2QR} - \lambda}{2QR} \right]^2 \geq \frac{1}{1+2QR} ,$$

The minimum value of $z(\lambda)$ is attained for $\lambda = \frac{1}{\sqrt{1+2QR}}$

Because we do not know the true value of $I(|c_1|^4)$, we analyze, for fixed λ , the possibilities

$$(a) \quad w(\lambda) \leq I(|c_1|^4) \leq z(\lambda)$$

$$(b) \quad z(\lambda) \leq I(|c_1|^4) .$$

If (b) holds, we apply (13) and (b) to deduce that

$$(15) \quad I(|c_1|) \geq \frac{1}{1+2QR} .$$

If (a) is true, we use a convexity argument to lower bound $I(|c_1|)$. (Then, the minimum of these lower bounds is a lower bound, for the given λ .) Then, by minimizing over all λ , we obtain the lower bound (18).

The convexity argument for case (b) is the well-known fact that, given a function f , the function $F(r)$, defined by

$$F(r) = \log \int |f(x)|^r dx ,$$

is convex. Hence,

$$\frac{1}{3}[F(4) - F(1)] \geq F(2) - F(1) .$$

It follows from this, by substituting c_1 for f , and using the integral I , that

$$(16) \quad I(|c_1|) \geq \frac{[I(|c_1|^2)]^{3/2}}{[I(|c_1|^4)]^{1/2}} .$$

Setting $x = I(|c_1|^4),$

$$y = I(|c_1|^2),$$

and $v = \frac{1+\lambda^2}{2},$

we see that our goal is to lower bound the function $\sqrt{\frac{y^3}{x}}$

over that part of the shaded region of figure 5, for which $x \leq z(\lambda)$. This will give, for each value of λ , a lower bound for $I(|c_1|)$, by (14). Letting

$$G(x, \lambda) = \frac{v+x-\lambda\sqrt{x}}{x^{1/3}},$$

(11) gives

$$\sqrt{\frac{y^3}{x}} \leq \left[\frac{G(x, \lambda)}{(1+QR)} \right]^{3/2} .$$

We give a lower bound for the function $G(x, \lambda)$, by first minimizing G with respect to x , for fixed λ , and then minimizing with respect to λ .

In fact, $G(x, \lambda)$ is minimized with respect to x , for fixed λ , at the point

$$x(\lambda) = \frac{1}{64} [\lambda + \sqrt{16+17\lambda^2}]^2 .$$

It follows that $G(x(\lambda), \lambda)$ is minimized, for all λ , when

$$\lambda = \sqrt{x} = \sqrt{1/2} .$$

We conclude , therefore, that if $w(\lambda) \leq x \leq z(\lambda)$,

then

$$(17) \ I(|c_1|) \geq \left[\frac{\frac{3}{4} \sqrt[3]{2}}{(1+QR)} \right]^{3/2} .$$

Now, (15) holds if $x \geq z(\lambda)$ and (17) holds if $w(\lambda) \leq x \leq z(\lambda)$. We conclude that, whatever the true true value of x and λ ,

$$(18) \ I(|c_1|) \geq \left(\frac{1}{(1+2QR)} \right) \wedge \left(\frac{3 \sqrt{3}}{4 \sqrt{2} (1+QR)^{3/2}} \right)$$

Remark: In section 4.6, we will improve this lower bound by deriving additional restrictions on the permissible values of x, y , and λ .

FIGURE 4

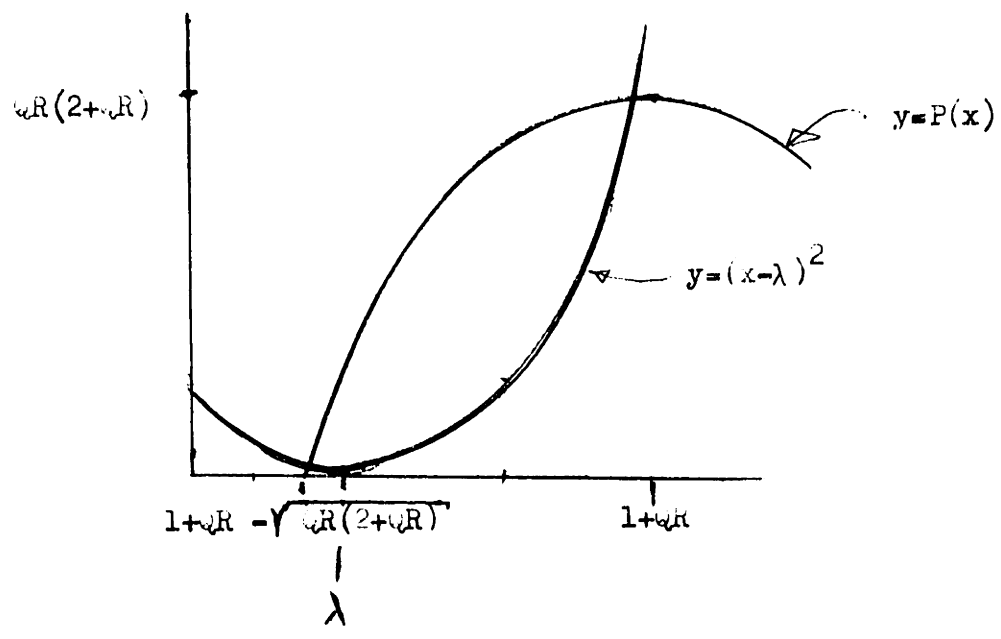
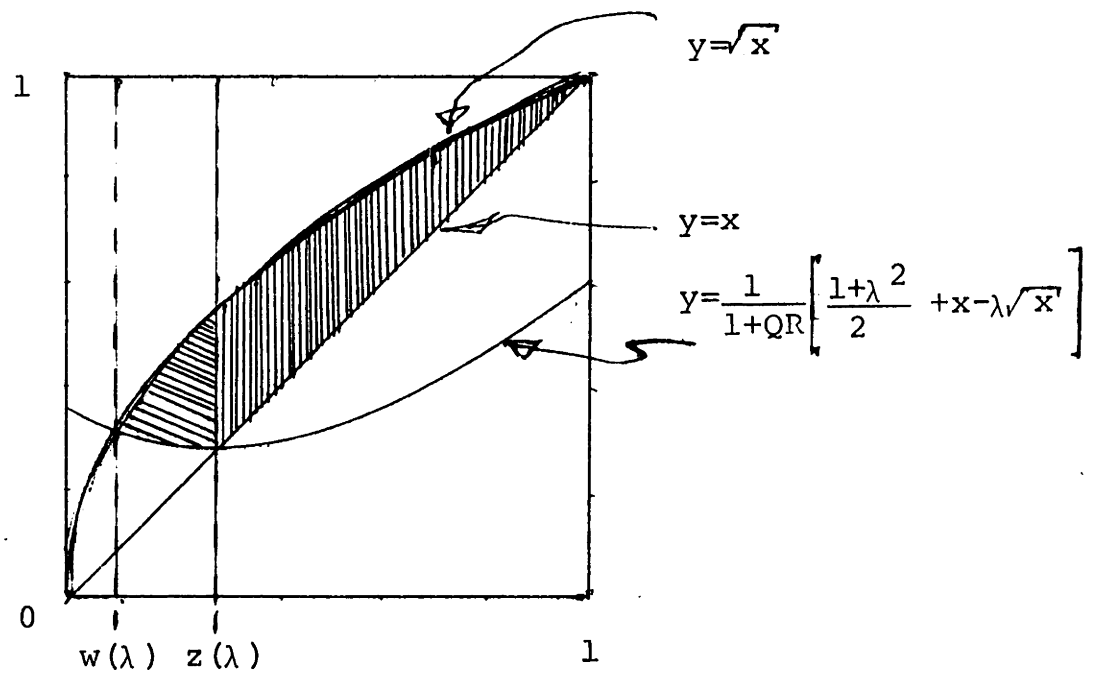

FIGURE 5



4.5 A conjecture and generalizations; a partial result; a counterexample

In this section, we do three things. We begin with a conjecture that $\text{Re}(E(c_1^2 \bar{c}_2)) \geq 0$ and suggest the generalized conjecture that

$$\text{Re}(E(c_n^2 \bar{c}_{n+1})) \geq 0, \text{ for all } n=1,2,3,\dots$$

Then, we support the conjecture by proving that

$$\text{Re}(c_1^2 \bar{c}_2) \geq 2|c_1|^4 - |c_1|^2 \geq -\frac{1}{8}$$

We conclude this section with a counterexample to the generalized conjecture.

We conjecture that $\text{Re}(E(c_1^2 \bar{c}_2)) \geq 0$. This has the following intuitive interpretation; The random variable c_1 is used to obtain an angle estimate $\hat{\theta}$, which, perhaps, maximizes $E(\text{Re}(e^{2i(\theta - \hat{\theta})}) | \mathcal{F}_t)$. (This is analagous to $\hat{\theta}$, which maximizes $E(\text{Re}(e^{i(\theta - \hat{\theta})}) | \mathcal{F}_t)$.) We observe that

$$\begin{aligned} c_1^2 \bar{c}_2 &= [E(e^{-i\theta} | \mathcal{F}_t)]^2 [E(e^{2i\theta} | \mathcal{F}_t)] \\ &= e^{2i(\hat{\theta} - \hat{\theta})} [E(e^{-i(\theta - \hat{\theta})} | \mathcal{F}_t)]^2 [E(e^{2i(\theta - \hat{\theta})} | \mathcal{F}_t)] \\ &= e^{2i(\hat{\theta} - \hat{\theta})} |c_1|^2 \cdot P, \text{ for } P > 0, \end{aligned}$$

by the assumption that $\hat{\theta}$ maximizes the conditional

expectation. These equations suggest that $\text{Re}(E(c_1^2 \bar{c}_2))$ measures the difference of the two estimates, $\hat{\theta}$ and $\hat{\theta}$.

We expect that these estimates will be close together if they

are good, so that

$$e^{i(\hat{\theta} - \hat{\theta})} \approx 1,$$

whence $\operatorname{Re}(E(c_1^2 \bar{c}_2)) \geq 0$.

The generalization of this conjecture is

$$\operatorname{Re}(E(c_1 c_n \bar{c}_{n+1})) \geq 0, \text{ for all } n.$$

A similar intuitive argument suggests that this would reflect the accuracy of estimates based on the higher order Fourier coefficients. We will show, however, that the generalized conjecture cannot be true if $QR=2$.

Although the generalized conjecture is generally false, and we cannot prove the conjecture, we now prove that

$$\operatorname{Re}(c_1^2 \bar{c}_2) \geq -\frac{1}{8}$$

In fact,

$$\begin{aligned} (1 - |c_1|)^2 &= [E(1 - \cos(\theta - \hat{\theta}) | \mathcal{F}_t)]^2 \\ &\leq E([1 - \cos(\theta - \hat{\theta})]^2 | \mathcal{F}_t). \quad (\text{Holder}) \end{aligned}$$

But

$$(1 - \cos \phi)^2 = \frac{3}{2} + \operatorname{Re}\left(\frac{e^{-2i\phi}}{2} - 2e^{-i\phi}\right),$$

so that

$$\begin{aligned} E([1 - \cos(\theta - \hat{\theta})]^2 | \mathcal{F}_t) &= \frac{3}{2} + \operatorname{Re}\left[\frac{c_2 e^{2i\hat{\theta}}}{2} - 2c_1 e^{i\hat{\theta}}\right] \\ &= \frac{3}{2} + \operatorname{Re}\left[\frac{c_1^2 \bar{c}_2}{2|c_1|^2} - 2|c_1|\right], \end{aligned}$$

because $|c_1| = c_1 e^{i\hat{\theta}}$.

Hence, combining these inequalities gives

$$(19) \operatorname{Re}(c_1^2 c_2) \geq 2|c_1|^4 - |c_1|^2.$$

But, for all real x , $2x^2 - x \geq -\frac{1}{8}$; the conclusion follows.

Counterexample: We now give a counterexample which shows that the generalized conjecture fails if $QR=2$.

If

$$E(\operatorname{Re}(c_1 c_n \bar{c}_{n+1})) \geq 0, \text{ for all } n, \text{ then by (6),}$$

$$QR I(|c_1|^2) \leq \frac{1}{2} [1 + I(|c_2|^2)]$$

and $QR I(|c_n|^2) \leq \frac{1}{2} [I(|c_{n-1}|^2) + I(|c_{n+1}|^2)] + I(|c_n|^2)$,
for $n > 1$.

Letting $x_n = I(|c_n|^2)$, to simplify the formulas,

$$x_1 \leq \frac{1}{2QR} [1 + x_2]$$

$$x_n \leq \frac{1}{2(QRn^2 - 1)} [x_{n-1} + x_{n+1}], \text{ for } n > 1.$$

We analyze this system of inequalities by considering the finite system:

$$x_1 \leq a_1 + b_1 x_2$$

$$x_n \leq a_n x_{n-1} + b_n x_{n+1}, \quad n=2, \dots, N-1$$

$$x_N \leq a_N x_{N-1} + b_N$$

subject to the condition that all a_n and b_n are non-negative.

By induction,

$$x_{N-k} \leq \frac{a_{N-k} x_{N-(k+1)}}{f_{N-k}} + g_{N-k}$$

where

$$f_N = 1$$

$$f_{N-k} = 1 - \frac{a_{N-(k-1)} b_{N-k}}{f_{N-(k-1)}}$$

$$g_{N-k} = \frac{b_N \dots b_{N-k}}{f_N \dots f_{N-k}}$$

Thus, for example,

$$x_1 \leq \frac{a_1}{f_1} + g_1 = \frac{a_1}{1 - \frac{a_2 b_1}{1 - \frac{a_3 b_2}{1 - \frac{a_4 b_3}{1 - \frac{a_5 b_4}{\dots}}}} + g_1$$

For the phase-tracking problem,

$$a_1 = b_1 = \frac{1}{2QR}$$

$$a_n = b_n = \frac{1}{2(QRn^2 - 1)}, \quad n > 1.$$

If $QR=2$, then

$$a_1 = b_1 = \frac{1}{4}$$

$$a_n = b_n = \frac{1}{2(2n^2-1)}, \quad n > 1$$

It follows that $g_n = 0$, for all n ,
and that $\lambda = \sqrt{x_2} \leq 0.135$.

But, by (11), $\lambda \geq 0.17$, a contradiction.

This concludes the counterexample.

4.6 Strengthening the bounds

We have just shown that the conjecture and the generalization must be generally false. Let us summarize the information which we do have. For x, y, λ , and v as in section 4.4:

$$(11) \quad QR + 1 - \sqrt{QR(2+QR)} \leq \lambda$$

$$(20) \quad v \geq x + QRy, \quad \text{because}$$

$$-(1+QR)y + v + x = I(\operatorname{Re}(c_1^2 \bar{c}_2)) \quad (7)$$

$$\text{and} \quad I(\operatorname{Re}(c_1^2 \bar{c}_2)) \geq 2x - y \quad (19)$$

$$(12) \quad y \geq F(x) \triangleq \frac{1}{1+QR} (v + x - \lambda\sqrt{x})$$

$$(10) \quad x \geq w(\lambda)$$

These inequalities are illustrated in Figure 6. The shaded region represents the values of the pair (x, y) which are permitted by these inequalities.

If the pair (x_0, y_0) , where

$$\frac{v - x_0}{QR} = F(x_0) = y_0$$

lies above the line $y = x$, we may invoke the convexity argument, introduced in section 4.4, to lower bound $I(|c_1|)$.

$$I(|c_1|) \geq \min_{\substack{\text{[permissible} \\ \text{pairs } (x, y)]}} \sqrt{\frac{y^3}{x}}$$

It is easy to see that the minimum is attained at (x_0, y_0) whenever (setting $f(x, y) = \frac{y^3}{x}$), the vector $\vec{\nabla}f(x_0, y_0)$ satisfies $\vec{\nabla}f(x_0, y_0) \cdot \vec{v} > 0$, for some vector $\vec{v} = (x_1 - x_0)\hat{i} + (y_1 - y_0)\hat{j}$, where (x_1, y_1) is a permissible pair.

Note that

$$x_0 = \frac{1}{4(1+2QR)^2} [QR\lambda + \sqrt{2(1+2QR) + \lambda^2(2+4QR+Q^2R^2)}]^2$$

$$y_0 = \frac{v - x_0}{QR}$$

This improves the bound obtained in section 4.4, because the region over which the function $f(x, y)$ need be minimized has been made smaller.

In section 4.7, we give examples of the use of the use of these bounds.

FIGURE 6

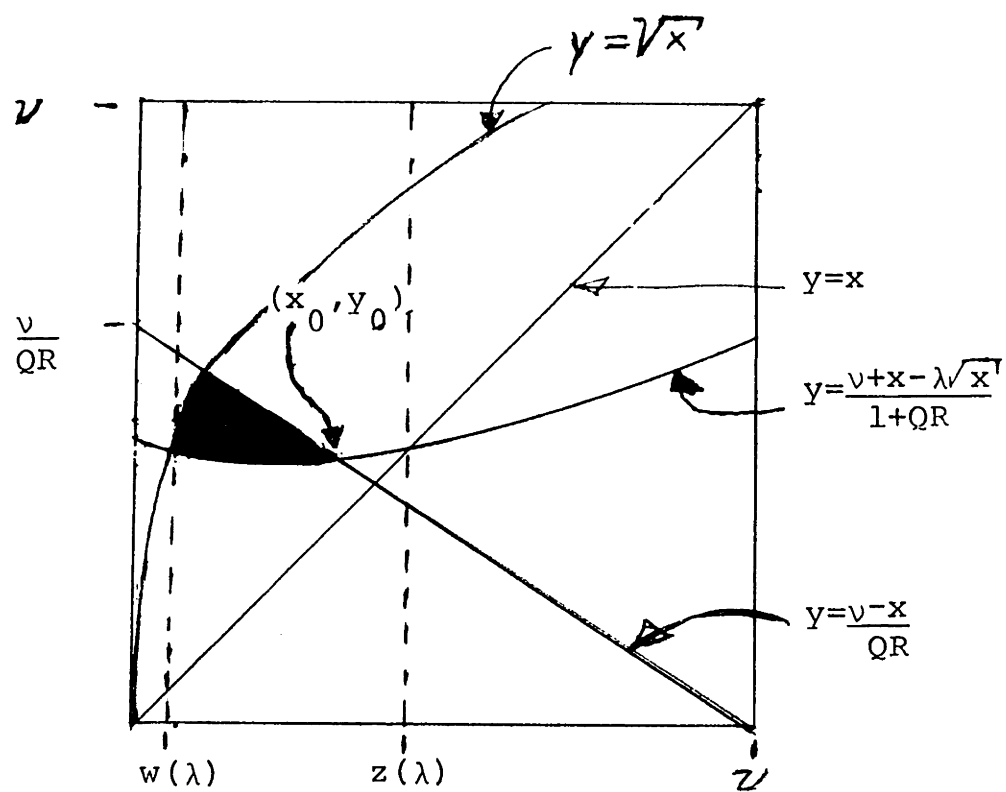

4.7 Comparison of results

In this section we compare our results with estimates of error bounds obtained by simulations for the following related phase-tracking problem:

The signal process satisfies

$$d\theta = \omega dt + \tilde{Q}^{1/2} dw$$

and there is a single observation process

$$dx = (\sin \theta) dt + \tilde{R}^{1/2} dv .$$

The goal is to find an estimate $\hat{\theta}$ of θ , which minimizes the conditional expectation

$$E(1 - \cos(\theta - \hat{\theta}) | \mathcal{F}_t) .$$

There are simulation results available for two estimators:

- (a) the classical phase-lock loop, and (b) a suboptimal filter proposed in [12].

We may compare our results with simulation results because we shall show how the above problem may be modified to give the one which we have studied. We argue non-rigorously; for details, the reader is referred to Van Trees [10] or Viterbi [11].

The observation process solves the differential equation

$$\frac{dx}{dt} = \sin(\omega t + \tilde{Q}^{1/2} w(t)) + \tilde{R}^{1/2} \frac{dv}{dt}$$

Multiplication by $(\sin \omega t)$ gives

$$\begin{aligned}
(\sin \omega t) \frac{dx}{dt} &= \frac{1}{2} [1 - \cos 2\omega t] \cos(\tilde{Q}^{1/2} \omega(t)) \\
&+ \frac{1}{2} [\sin 2\omega t] \sin(\tilde{Q}^{1/2} \omega(t)) \\
&+ \tilde{R}^{1/2} (\sin \omega t) \frac{dv}{dt} .
\end{aligned}$$

This signal is now passed through a low-pass filter to remove the double-frequency ($2\omega t$) terms. Moreover, we claim that the process

$$\tilde{R}^{1/2} (\sin \omega t) \frac{dv}{dt}$$

may be replaced by

$$\left[\frac{\tilde{R}}{2} \right]^{1/2} \frac{dv_1}{dt} ,$$

for the standard Brownian motion process $v_1(t)$.

Thus, we have an observation

$$s_1(t) = \frac{1}{2} \cos(\tilde{Q}^{1/2} \omega(t)) + \left[\frac{\tilde{R}}{2} \right]^{1/2} \frac{dv_1}{dt} .$$

Setting $s_1 = \frac{1}{2} \frac{dz_1}{dt}$ gives

$$dz_1 = \cos(\tilde{Q}^{1/2} \omega(t)) dt + (\tilde{R})^{1/2} dv_1 .$$

If we multiply the original observation process by $(\cos \omega t)$ and argue in a similar way, we obtain

$$dz_2 = \sin(\tilde{Q}^{1/2} \omega(t)) dt + (\tilde{R})^{1/2} dv_2 .$$

We have shown that the phase-tracking problem with a

single observation may be compared with the one which we have studied, provided that we set $Q=\tilde{Q}$ and $R=2\tilde{R}$, where \tilde{Q} and \tilde{R} are the noise strengths for the single-observation problem and Q and R are the strengths for the problem considered in this thesis.

We tabulate results in Figure 7. The first two columns are taken from Willsky []. They are estimates of the filter error based on simulation of two techniques: the classical phase-lock loop and a filter proposed in []. The third column contains the lower bound of inequality (18). The fourth column contains, for the cases $QR=1.0$ and $QR=1.7$, a bound obtained by applying the results of section 4.6.

In applying the result of section 4.6, one issue is to obtain tight bounds for $\lambda = \sqrt{I(|c_2|^2)}$. To obtain a lower bound for λ , we use (11). For the upper bound, we use the infinite system of equations (6) to derive the infinite system of inequalities

$$(QRn^2 - 1)I(|c_n|^2) \leq \frac{1}{2} [I(|c_{n-1}|^2) + I(|c_{n+1}|^2)] \\ + \sqrt{I(|c_n|^2)} [\sqrt{I(|c_{n-1}|^2)} + \sqrt{I(|c_{n+1}|^2)}]$$

These follow from the Holder inequality and the fact that

$|c_n| \leq 1$. We also use

$$(18) \quad I(|c_1|^2) \leq \frac{1 + I(|c_2|^2)}{2QR}$$

By starting with the knowledge that $I(|c_n|^2) \leq 1$, for all n , these inequalities may be used to give smaller bounds.

These may, in turn, be used to give still smaller ones. By continuing this iteration, it is possible to show, for example, that if

$$QR=1.7, \text{ then } I(|c_1|^2) \leq 0.311 \text{ and } I(|c_2|^2) \leq 0.056,$$

so that $\lambda \leq 0.237$. Hence, we have $\lambda \in [0.19, 0.24]$.

By using the argument of section 4.6 to limit the region of permissible values of x and y , and by invoking the convexity argument, we may show that $I(|c_1|) \geq 0.26$.

This gives the bound for the phase-tracking problem of

$$\lim_{T \rightarrow \infty} \frac{1}{T} \int_0^T E[1 - \cos(\theta(t) - \hat{\theta}(t))] dt \leq 0.74,$$

which compares very unfavorably with the estimates obtained by simulation.

It should be noted that the iteration procedure for upper bounding is useful only for large values of QR . In the case of $QR=1$, it seems difficult to improve significantly the bound $\lambda \in [0.26, 0.59]$.

FIGURE 7

0.0169	0.0608	0.0581	0.10	
0.0506	0.1171	0.1120	0.15	
0.16	0.2447	0.2253	0.26	
0.49	0.4098	0.3687	0.49	
1.0	0.5312	0.5002	0.68	0.67
1.69	0.6158	0.5692	0.79	0.74
QR	SIMULATION FOR PHASE-LOCK LOOP	SIMULATION FOR SUBOPTIMAL FILTER	SECTION 4.4	SECTION 4.6
	ESTIMATES OF $1-I(c_1)$		UPPER BOUND FOR $1-I(c_1)$	

5. Conclusions

It is our belief, upon observing the weakness of the error bounds obtained by our technique, that there must exist better ways to obtain bounds for the nonlinear filtering problem. The weakness of the method used here must lie in the convexity argument. It cannot generally give a bound sufficiently tight as to be useful. The only way suggested by the technique for improving the bound is to obtain more information which further constrains the set of permissible values of the random variables and numbers which we have used in our arguments (for example, $I(|c_1|^2)$). One way to do this might be with the conjecture of section 4.5. Of course, this should not be attempted before learning how the bounds may be improved, by applying the conjecture.

REFERENCES

- [1] B.Z. Bobrovsky and M. Zakai, "A Lower Bound for the Estimation Error for Certain Diffusion Processes," Memorandum No. ERL-M490, Elec, Res. Lab., University of California, Berkeley, October 1974.
- [2] R.S. Bucy and A.J. Mallinckrodt, "An Optimal Phase Demodulator," Stochastics, Vol. 1, 1973, pp. 3-23.
- [3] M. Fujisaki, G. Kallianpur, and H. Kunita, "Stochastic Differential Equations for the Nonlinear Filtering Problem," Osaka J. Math., Vol. 9, 1972, pp. 19-40.
- [4] A.S. Gilman and I.B. Rhodes, "Cone-Bounded Non-linearities and Mean Square Bounds--Estimation Upper Bound," IEEE Trans. on Automatic Control, Vol. AC-18, No. 3, June 1973, pp. 260-265.
- [5] I.B. Rhodes and A.S. Gilman, "Cone-Bounded Nonlinearities and Mean Square Bounds--Estimation Lower Bound," IEEE Transactions on Automatic Control, Vol. AC-20, No. 5, October 1975, pp. 632-42.
- [6] H. Kunita, "Asymptotic Behavior of the Nonlinear Filtering Errors of Markov Processes," J. Multivariate Analysis, Vol. 1, 1971, pp. 365-93.
- [7] F. Levieux, Filtrage Non-lineaire et Analyse Fonctionnelle, Rapport de Recherche no. 57, IRIA, February 1974.
- [8] S.I. Marcus, "Estimation and Analysis of Nonlinear Stochastic Systems," Ph.D. dissertation, Dep. Electrical Engineering, M.I.T., Cambridge, Mass., May 1975.
- [9] D.L. Snyder and I.B. Rhodes, "Filtering and Control Performance Bounds with Implications for Asymptotic Separation," Automatica, Vol. 8, No. 6, November 1972, pp. 747-53.

- [10] H.L. Van Trees, Detection, Estimation, and Modulation Theory--Part II: Nonlinear Modulation Theory. New York: Wiley, 1971.
- [11] A.J. Viterbi, "Phase-Locked Loop Dynamics in the Presence of Noise by Fokker-Planck Techniques," Proc. IEEE, Vol. 51, 1963, pp. 1737-53.
- [12] A.S. Willsky, "Fourier Series and Estimation on the Circle with Applications to Synchronous Communication--Part II: Implementation," IEEE Trans. on Information Theory, Vol. IT-20, No. 5, September 1974, pp. 584-590.
- [13] A.S. Willsky and S.I. Marcus, "Analysis of Bilinear Noise Models in Circuits and Devices," Monograph of the Colloquium on the Application of Lie Group Theory to Nonlinear Network Problems, April 1974, IEEE Pub. No. 74 CHO 917-5 CAS.
- [14] M. Zakai and J. Ziv, "Lower and Upper Bounds on the Optimal Filtering Error of Certain Diffusion Processes," IEEE Trans. on Information Theory, Vol. IT-18, No. 3, May 1972, pp. 325-31.